



JazzZ

VISUAL ALUMINIUM EXCELLENCE

GUIDEBOOK SEMI-FINISHED PRODUCTS

Way Finding Solutions

Features



Revolutionary, curved modular.

A new and curved product line.

The JazZ product line is the surpass within the Triline gamut.

The Curved, futurist like concept provides an extra dimension in wayfinding.

- Triangular aluminium side track with finishing caps
- 8 standard heights with possibility to expand
- 5 standard heights in insert profiles
- 2 variable insert profiles adaptable to any size
- Wall Signs
- Suspended Signs
- Anti-theft features
- Modular with inexhaustible combinations
- Simple aluminium system complying with architectural expectations and safety regulations





TriLine®



























































JazzZ

ALU
VISUAL ALUMINIUM EXCELLENCE



	page
Aluminium profiles & Synthetic parts	3.2
Assembling	3.4
Door Signs	3.6
Wall Signs	3.7
Suspended signs	3.8
Directory signs	3.10

Bendinglength

155 mm / 6.10"	180 mm / 7.09"	300 mm / 11.81"	480 mm / 18.90"	600 mm / 23.62"
 TLJ31-155-B	 TLJ31-180-B	 TLJ31-300-B	 TLJ31-480-B	 TLJ31-600-B
 TLJ31S-155-B	 TLJ31S-180-B	 TLJ31S-300-B	 TLJ31S-480-B	 TLJ31S-600-B
 TLJ62-155-B	 TLJ62-180-B	 TLJ62-300-B	 TLJ62-480-B	 TLJ62-600-B
 TLJ62S-155-B	 TLJ62S-180-B	 TLJ62S-300-B	 TLJ62S-480-B	 TLJ62S-600-B
 TLJ93-155-B	 TLJ93-180-B	 TLJ93-300-B	 TLJ93-480-B	 TLJ93-600-B
 TLJ93S-155-B	 TLJ93S-180-B	 TLJ93S-300-B	 TLJ93S-480-B	 TLJ93S-600-B
 TLJ124-155-B	 TLJ124-180-B	 TLJ124-300-B	 TLJ124-480-B	 TLJ124-600-B
 TLJ155-155-B	 TLJ155-180-B	 TLJ155-300-B	 TLJ155-480-B	 TLJ155-600-B
 TLJ155S-155-B	 TLJ155S-180-B	 TLJ155S-300-B	 TLJ155S-480-B	 TLJ155S-600-B
-	-	 TLJ186-300-B	 TLJ186-480-B	 TLJ186-600-B
-	-	 TLJ217-300-B	 TLJ217-480-B	 TLJ217-600-B
-	-	 TLJ217-300-B	 TLJ217-480-B	 TLJ217-600-B
-	-	 TLJ248-300-B	 TLJ248-480-B	 TLJ248-600-B

"JazZ profiles can be ordered in colours; please contact your local distributor for available colours, prices and delivery terms."

Aluminium profiles & Synthetic parts

JazZ profiles

Article code	width frame	Insert measures
TLJ31-...-B	31mm / 1.22"	-
TLJ31S-...-B	31mm / 1.22"	23mm / 1.02"
TLJ62-...-B	62mm / 2.44"	-
TLJ62S-...-B	62mm / 2.44"	57mm / 2.24"
TLJ93-...-B	93mm / 3.66"	-
TLJ93S-...-B	93mm / 3.66"	88mm / 3.46"
TLJ124-...-B	124mm / 4.88"	-
TLJ155-...-B	155mm / 6.1"	-
TLJ155S-...-B	155mm / 6.1"	149,4mm / 5.88"
TLJ186-...-B	186mm / 7.3"	-
TLJ217-...-B	217mm / 8.54"	-
TLJ217S-...-B	217mm / 8.54"	212mm / 8.35"
TLJ248-...-B	248mm / 9.76"	-

Suspension system

The connecting parts of the suspension system TLJOPH are made of aluminium in order to guarantee safety in case of fire, and to perform easy and smooth maintenance and / or replacement of suspension signs. The steelwire of 1.5mm/0.06" thickness has a portable force of 160kg/350 pounds (tested).

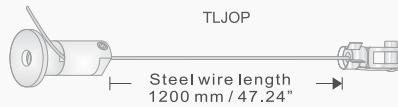

Clips

TLCLJ is a patented clip to be used in combination with the TLJAZ2 side track and single synthetic end caps. These clips guarantee an extensive flexibility, without breaking



TLCLJ-B

Side track profile

Can be used in any application, both in small door signs and in larger overview panels.



(Patented) TLJAZ2-B

Blocking pin / side tracks

TLAND is a patented anti-theft blocking pin for securing all types of wall mounted signs assembled with side tracks.

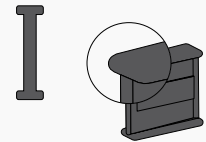

TLAND-B

Side track caps

Only to be used in combination with side track profiles. TLJAZS with TLJAZ2



TLJAZS-B

Screw

TLSCR3 is used to lock the side track caps and to ensure the correct blocking of the TLCLJ clips in the side tracks.



TLSCR3

Panel & supporting profile

These variable insert profiles offer the possibility to create any type and measure of insert panels larger than A4 (for example A3, A2, A1), and to integrate for example maps in large directories.



TLPAN-B

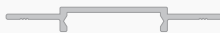

TLONP-B

These can be ordered on request
Standard bending lengths are:
155, 180, 300, 480 and 600mm

Triline® Key

TLKEY is created to unlock the profiles from their clips and replace a profile in a sign without disassembling the signs.

The key has a stainless steel insert piece with a synthetic handle.



TLKEY

Decipher the Triline® code

JazZ profiles

TL = Triline®

J = JazZ "curved"

155 = 155mm width profile

S = insert profile

-480 = 480mm profile length

-B = mill finish

Triline® KEY

Note:

The Triline® key cannot remove profiles which have been locked with the TLAND-B blocking pin!

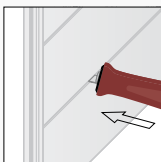

- 1 The Triline key needs to be slid horizontally between the profiles, at minimum 50mm distance from the side tracks.

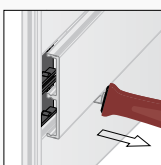

- 2 Pull the key backwards, the profile is now released from the clips and can be removed from the sign.

Assembling

The JazZ “curved” profiles (face and/or insert) will be snapped on the clips which have previously been integrated in the “JazZ” side tracks, and finished with side track caps.

Anti-theft solution: synthetic blocking pin that slides between clips.

Ideal for personnel signs, room identification, directional signs, and more...



MOUNTING POSSIBILITIES	
Wall	
1	With screw and plug.
2	Double tape (At01), to be used with special cleaning product (Ac02).
3	Glued with Sticky Bond (Ag01)

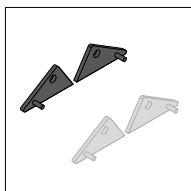

Side track caps
Standard colours

- Black
- Grey

Please contact your local distributor for other colours, prices and delivery terms.



Profiles have a standard length of 3500mm / 137.80"
Standard finishes

- Mill finish
- Silver anodized
- Gold anodized

Please contact your local distributor for other finishes, lengths, prices and delivery terms.

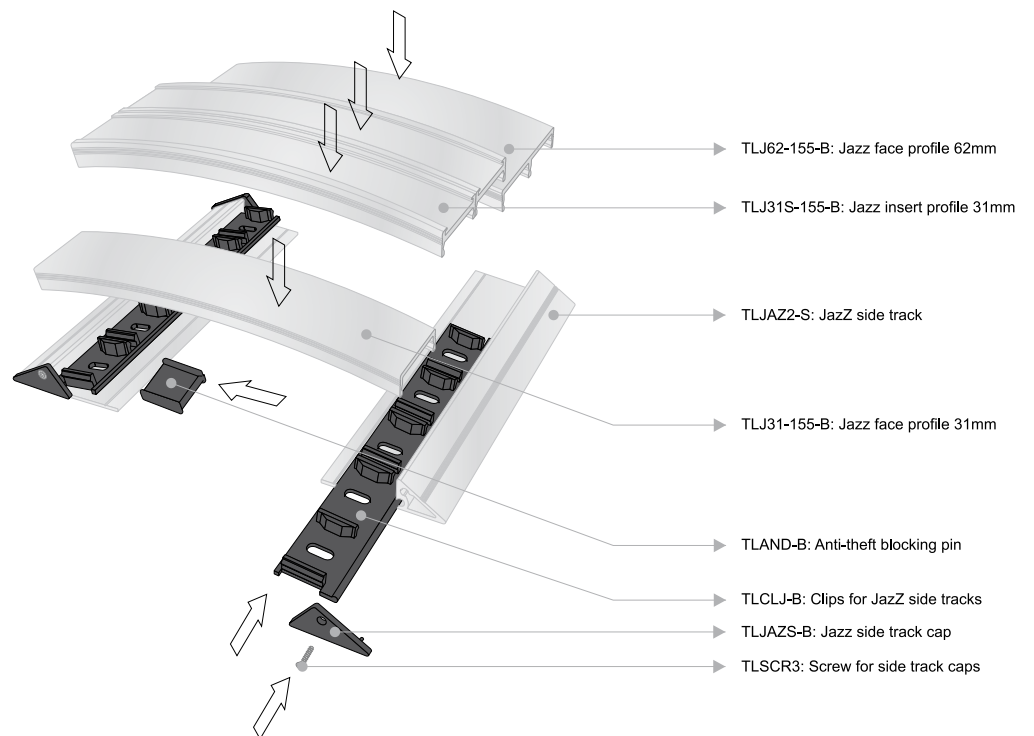

Cross-section
JazZ side tracks

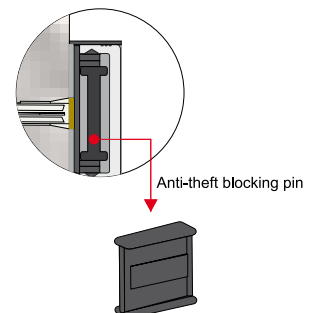

JazZ

Suspended Jazz signs

Assembling

The Jazz side tracks will be fixed together with At02 (double face tape specially for aluminium). In combination with the TLJOP, the sign can be mounted suspended.
 Suspended Jazz signs: 155, 180, 300, 480 and 600mm length.
Anti-theft solution: synthetic blocking pin that slides between clips.
 Ideal for personnel signs, directional signs and more...

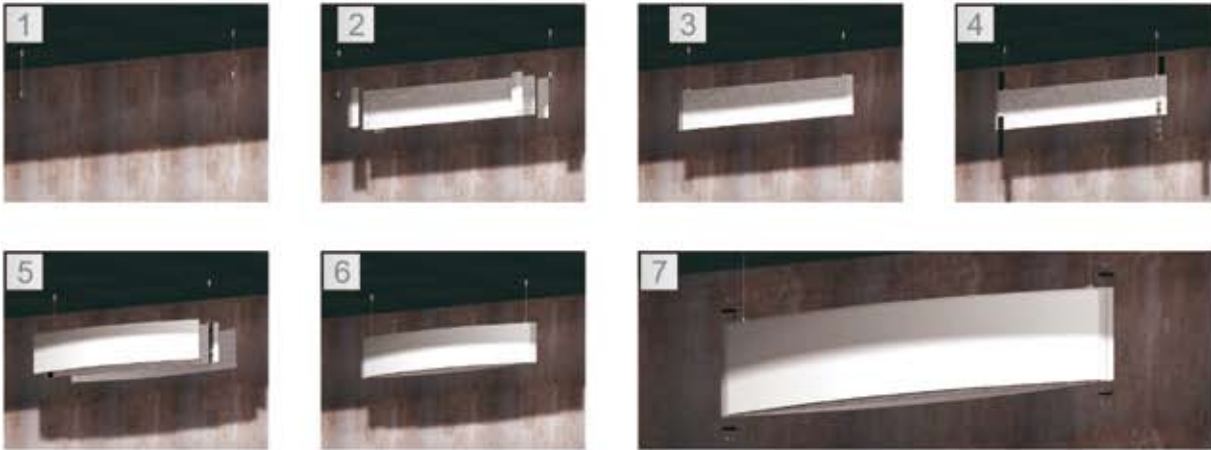

MOUNTING POSSIBILITIES
Suspended
With screw and plug.

APPLICATIONS
Jazz profiles
Vinyl lettering
Digital printing
Screen printing

INSERTS
Triline® profiles
The insert profiles offer the possibility to insert any kind of material with a thickness up to 1.75mm / 0.069".

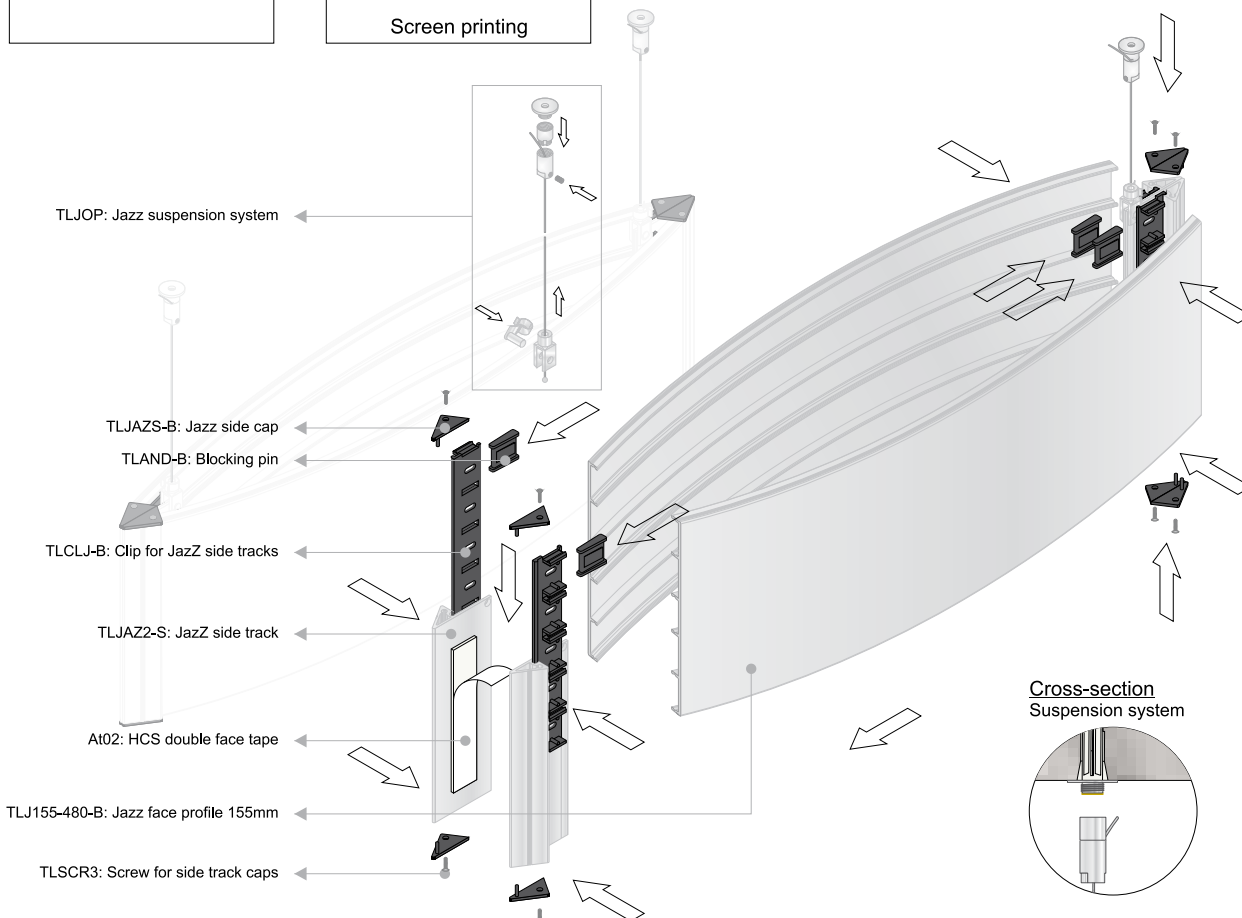

Jazz



93

	155mm	180mm	300mm
62mm 31mm	Dj101	Dj102	Dj103
62mm 31mm s	Dj104	Dj105	Dj106

124

	155mm	180mm	300mm
62mm 31mm 31mm	Dj107	Dj108	Dj109
62mm 31mm s 31mm s	Dj110	Dj111	Dj112
93mm 31mm	Dj113	Dj114	Dj115
93mm 31mm s	Dj116	Dj117	Dj118

155

	155mm	180mm	300mm
62mm 31mm 31mm 31mm	Dj119	Dj120	Dj121
62mm 31mm s 31mm s 31mm s	Dj122	Dj123	Dj124
93mm 31mm 31mm	Dj125	Dj126	Dj127
93mm 31mm s 31mm s	Dj128	Dj129	Dj130

Extra

	155mm	180mm	300mm
31mm	Exj101	Exj102	Exj103
31mm s	Exj104	Exj105	Exj106



480mm		600mm		
	Wj101		Wj108	62
				62mm
480mm		600mm		93
	Wj102		Wj109	
				93mm
480mm		600mm		124
	Wj103		Wj110	
				124mm
480mm		600mm		155
	Wj104		Wj111	
				155mm
480mm		600mm		186
	Wj105		Wj112	
				186mm
480mm		600mm		217
	Wj106		Wj113	
				217mm
480mm		600mm		248
	Wj107		Wj114	
				248mm
480mm		600mm		Extra
	Exj107		Exj111	31mm
	Exj108		Exj112	31mm s
	Exj109		Exj113	62mm
	Exj110		Exj114	62mm s

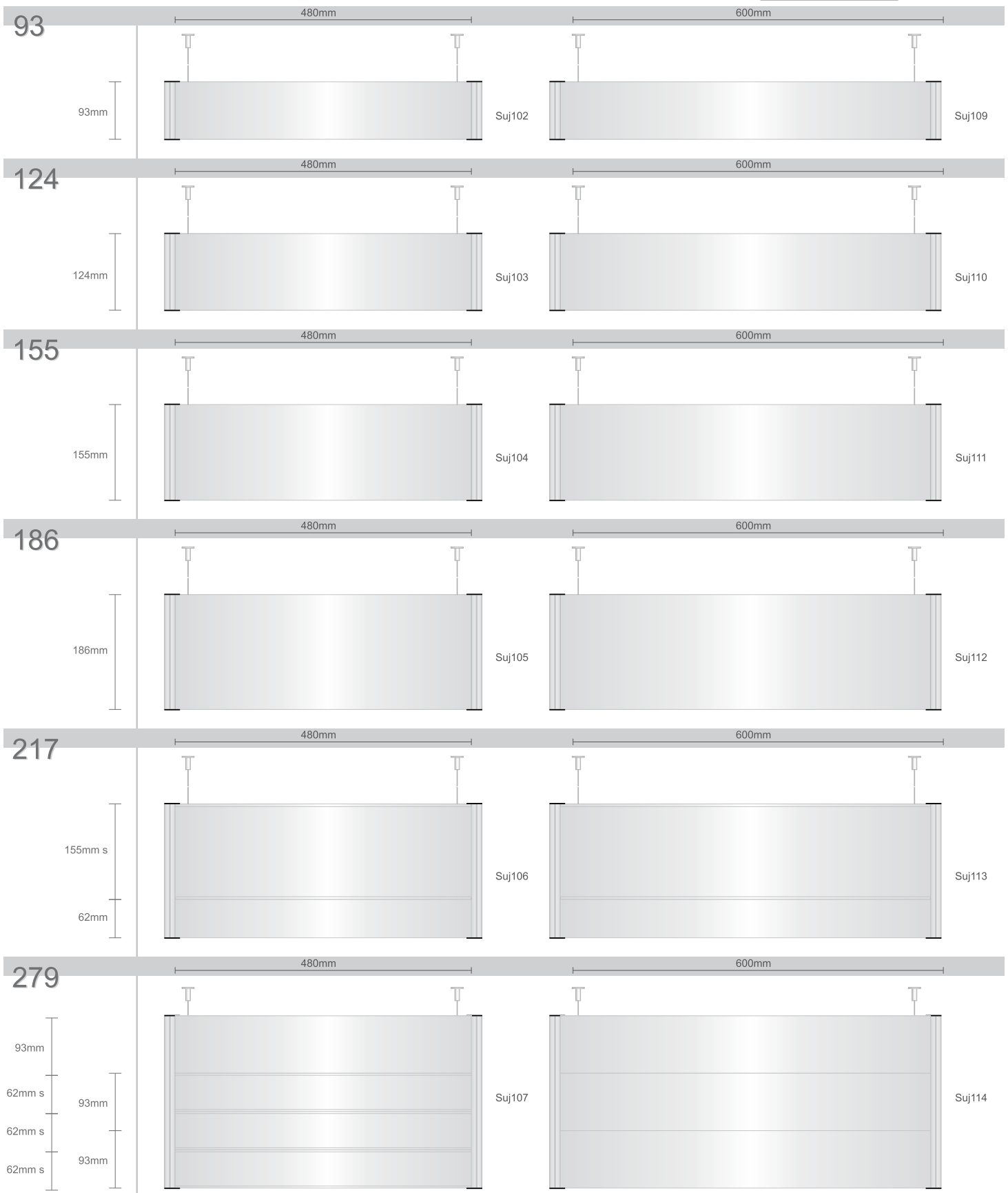

"S" indicates insert profiles

This is only a selection of the endless combination possibilities that the Triline® system offers. You can't find what you need? Contact us and we will help you to find the solution!

Extra profiles to extend yours suspended signs



480mm	600mm			
31				
	Esuj101		Esuj111	31mm
	Esuj102		Esuj112	31mm s
62				
	Esuj103		Esuj113	62mm
	Esuj104		Esuj114	62mm s
93				
	Esuj105		Esuj115 93 x 600mm	93mm
	Esuj106		Esuj116	93mm s
124				
	Esuj107		Esuj117	124mm
155				
	Esuj108		Esuj118	155mm
	Esuj109		Esuj119	155mm s
186				
	Esuj110		Esuj120	186mm

Note: The extra profiles can be used to extend the door, wall or suspended sign examples showed in this catalog.

For example: You need a suspended JazZ sign of 600mm length with a top profile of 155mm and five insert profiles of 62mm.

Your order: 1x (Suj111 + (5 x Esuj114)) =
One suspended JazZ sign of 465 x 600mm,
a face profile of 155 and five insert profiles of 62mm with a length of 600mm.
Double face sign.

"S" indicates insert profiles

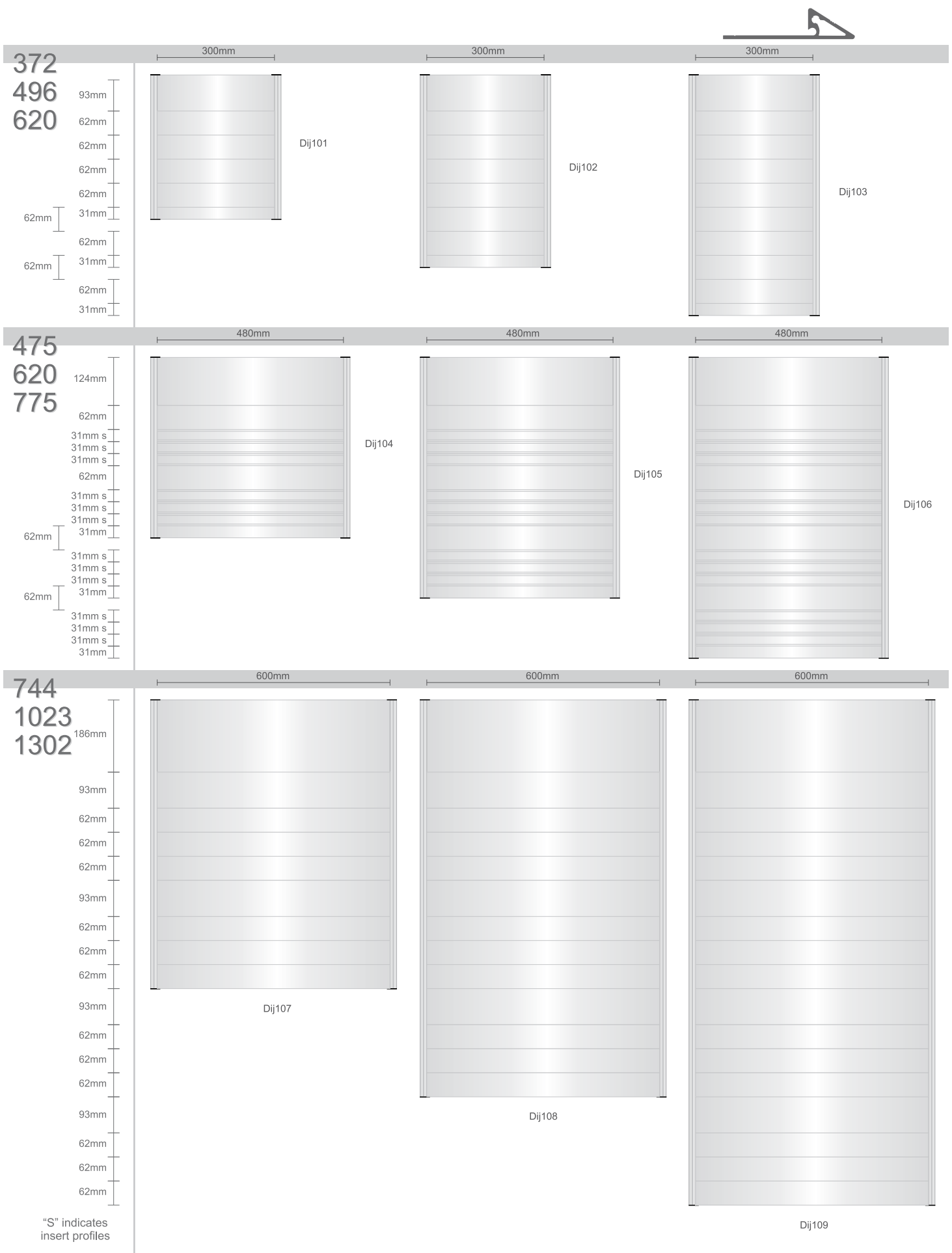



A series of horizontal dotted lines providing a template for writing or drawing.

